

Flush-mount multifunction pressure transmitter CPE 310-S

KEY POINTS

- Measuring Ranges
 - CPE 310-S : from -100 to +100 Pa
 - CPE 311-S : from -1000 to +1000 Pa
- Input for interchangeable probe (Class 310)
- Alternating display of 1 to 3 parameters
- Front face calibration
- Configurable intermediate and centre zero ranges
- 3 audible and visual alarms
- Front face keypad allowing to configure the transmitter and acknowledge the alarm
- 3 analogue outputs 0-5/10 V or 0/4-20 mA
- High resolution in pressure on model -100/+100 Pa (ex : 0.1 Pa) (optional)
- Outputs diagnostic
- MODBUS network RS485 system (optional)
- Front face made of brushed stainless steel with electroluminescent display



FEATURES OF THE HOUSING

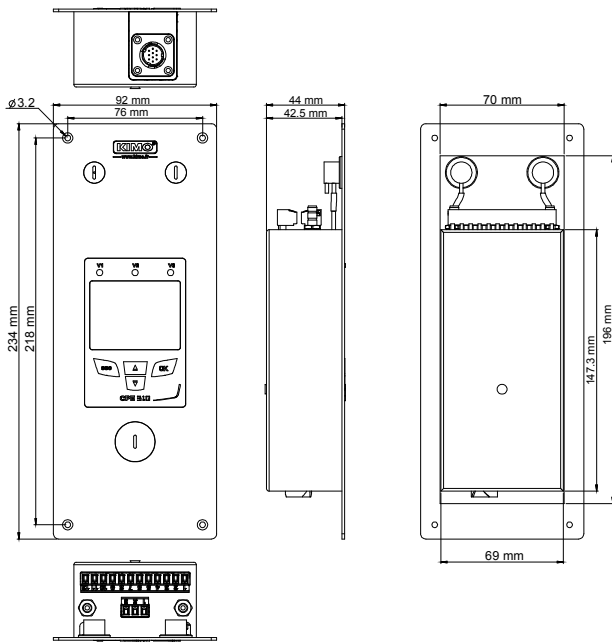

Front face : Brushed stainless steel 316 L

Back housing : Flush-mount in stainless steel 304 L

Protection : IP65 in front face

Display : Electroluminescent alphanumeric (38 x 48 mm)
Protection screen made of inactive red PMMA

Height of the digits : 14 mm

Back fittings : Barbed fitting \varnothing 5.2 mm

Weight : 640 g

TECHNICAL FEATURES IN PRESSURE

Measuring range	CPE 310- S : from -100 to +100 Pa CPE 311-S : from -1000 to +1000 Pa
Measurement units	Pa, mmH ₂ O, mbar, inWG, mmHG, daPa, hPa
Accuracy*	CPE 310-S : $\pm 0.2\%$ of reading ± 0.8 Pa CPE 311-S : $\pm 0.2\%$ of reading ± 2 Pa
Zero drift	None (see "Self-calibration")
Resolution	1 Pa, 0.1 mmH ₂ O, 0.01 mbar, 0.01 inWG, 0.01 mmHG, 0.1 daPa, 0.01 hPa
Auto-calibration	Manual or automatic (configurable)
Allowed overpressure	25 000 Pa
Response time	1/e (63%) 0.3 s
Type of fluid	Air and neutral gases

*All accuracies indicated in this document were stated in laboratory conditions and can be guaranteed for measurements carried out in the same conditions, or carried out with calibration compensation.

TECHNICAL SPECIFICATIONS

Power supply	24 Vac / Vdc $\pm 10\%$
Output	3 x 0/4-20 mA or 3 x 0-5/10 V (4 wires) Common mode voltage Maximum load : 500 Ohms (0/4-20 mA) / Minimum load : 1 K Ohms (0-5/10 V)
Galvanic isolation	On the output
Consumption	5 VA
Conformity	2004/108/EC EMC ; 2006/95/EC Low Voltage ; 2011/65/EU RoHS II ; 2012/19/EU WEEE
Electrical connection	Screw terminal block for cables from 0.05 to 1.5 mm ² or from 30 to 16 AWG Carried out according to the code of good practice.
RS485 communication	Digital : Modbus RTU protocol, configurable communication speed from 2400 to 115200 Bauds (optional)
Visual alarm	Blinking of the value
Audible alarm	Buzzer (70 dB at 10 cm)
Environment and type of fluid	Air and neutral gases
Conditions of use (°C/%RH/m)	From -10 to +50 °C. In non-condensing condition. From 0 to 2000 m
Storage temperature	From -10 to +70 °C

SELF-CALIBRATION

Class 310 transmitters have a temperature compensation system from 0 to 50°C and a self-calibration system to guarantee an excellent long-term stability, along with a great measurement accuracy.

Self-calibration principle : the microprocessor of the transmitter drives a solenoid valve that compensates any long-term drifts of the sensitive element. The compensation is made by regular adjustment of the zero. The differential pressure measurement is then made regardless of the environmental conditions of the transmitter.

Solenoid valve lifetime : 100 million cycles

Advantage : no zero drift

Self-calibration frequency : can be disabled or set from 1 to 60 min

INNOVATIONS

> Adjustable pressure connections

The CPE310-S and CPE 311-S transmitter have a **two adjustable pressure connections system** in front face (A) coupled with two pressure connections at the back (B). When installing the transmitter, this system allows to configure the differential pressure connections with a set of plugs (supplied with the transmitter).

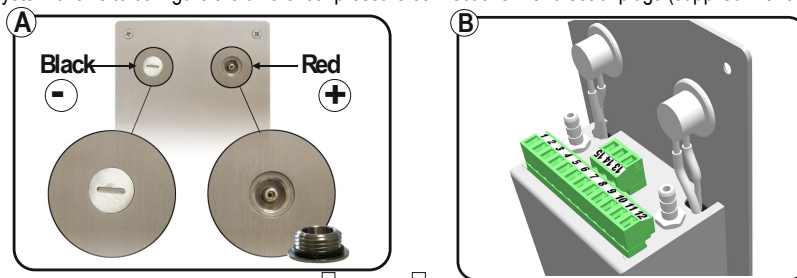

> Front face calibration

This system allows to isolate the back pressure connections and then to access the sensitive element (on the front face) of the pressure transmitter. Without dismantle the transmitter, this system allows to calibrate by connecting the transmitter to a pressure generator and a calibration bench. The calibration is easier and faster.

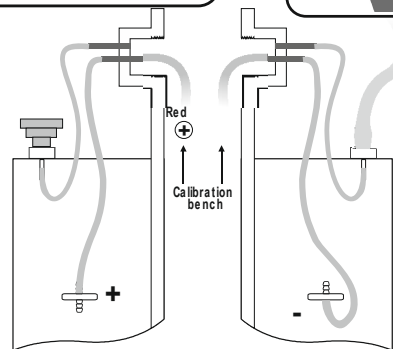

> Front face computer connection

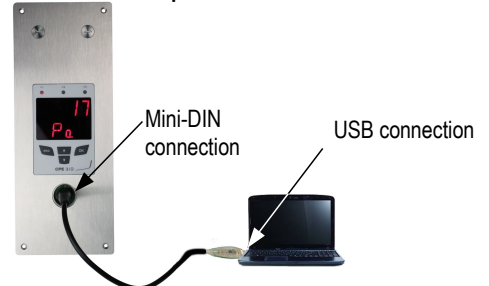

CONFIGURABLE ANALOGUE OUTPUTS

Configurable analogue outputs :

Range with centre zero (-50/0/+50 Pa), with offset zero (-30/0/+70 Pa) or standard range (0/+100 Pa), it is possible to configure your own intermediate ranges. The minimum configurable range is 10% of the full scale.

Configurable ranges according to your needs : outputs are automatically adjusted to the new measuring ranges

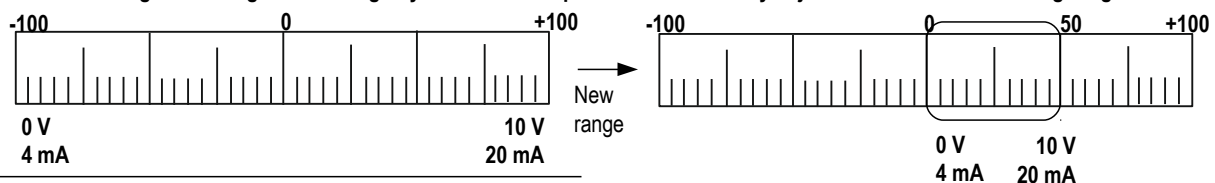

ALARMS

The CPE310-S and CPE311-S pressure transmitter have 3 visual and audible alarms that are independent and configurable. Available settings are the followings :

- Time-delay duration : from 0 to 600 s
- Thresholds values
- Action of the alarm : rising edge, falling edge or monitoring
- Audible alarm activation (buzzer)

INTEGRATION OF PRESSURE MEASUREMENT

The pressure measurement element is very sensitive and reacts to pressure changes. When making measurements in unstable air movement conditions, the pressure measurement may fluctuate. The integration coefficient (from 0 to 9) makes an average of the measurements ; this helps to avoid any excessive variations and guarantees a stable measurement.

POSSIBLE OPTIONAL MEASUREMENTS

The following probes and boards are available as option for C310 transmitters. For further details please see the technical datasheet of probes for class 310 transmitters.

Probes	Measuring ranges
Stainless steel or polycarbonate hygrometry / temperature probe	From 0 to 100%RH and from -40 to +180 °C (according to probe)
Air velocity vane probe : air velocity / temperature / airflow	From -5 to 35 m/s (according to probe) / From -20 to +80 °C / From 0 to 99 999 m ³ /h
Air velocity hotwire probe : air velocity / temperature / airflow	From 0 to 30 m/s / From -20 to +80 °C / from 0 to 99 999 m ³ /h
Omnidirectional probe : air velocity / temperature	From 0 to 5 m/s and from 0 to 50 °C
Pt100 1/3 DIN temperature probe	From -50 to +180 °C / From -20 to +80 °C
CO / temperature probe	From 0 to 500 ppm and from 0 to 50 °C
CO ₂ / temperature probe	From 0 to 20 000 ppm and from 0 to 50 °C

CONNECTIONS

Modbus :

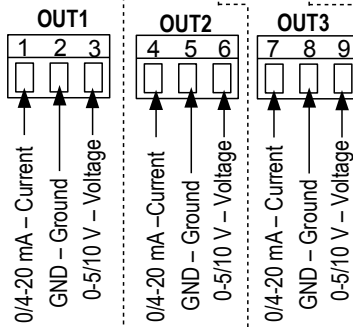
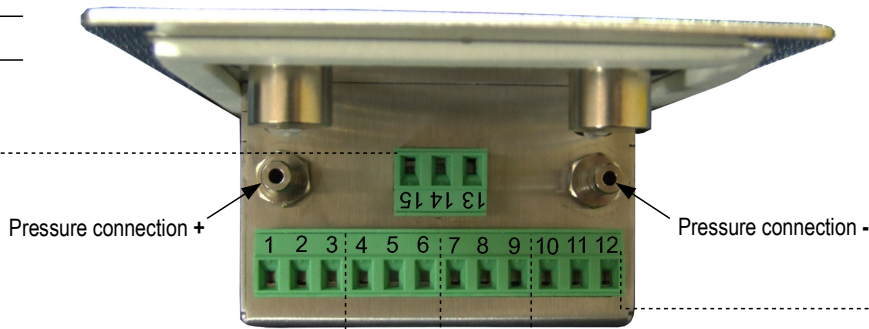
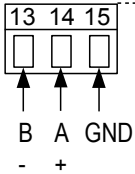

Power supply terminal block

For 24 Vdc power supply models :

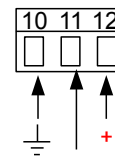

For 24 Vac power supply models :

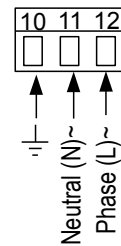

ELECTRICAL CONNECTIONS – as per NFC15-100 standard



This connection must be made by a qualified technician. To make the connection, the transmitter must not be energized.

> For 24 Vdc power supply models :

Power supply terminal block

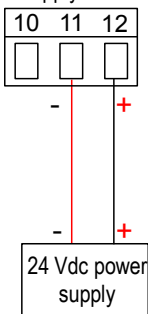

> For 24 Vac power supply models :

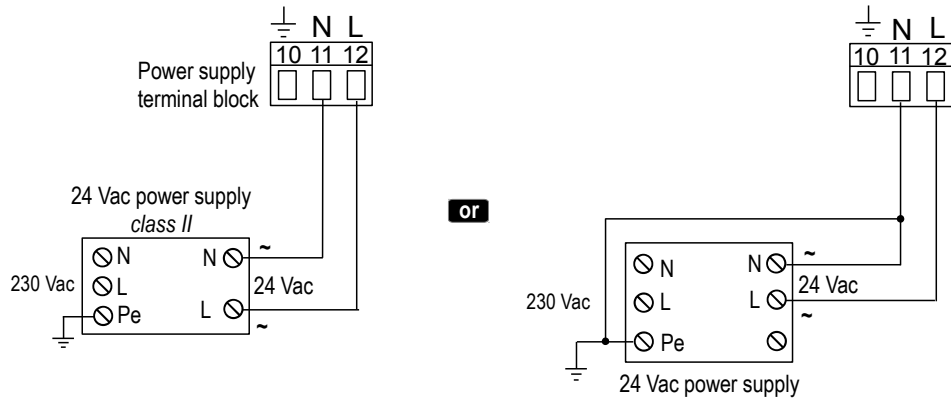

> Connection of the 0/4-20 mA current output :

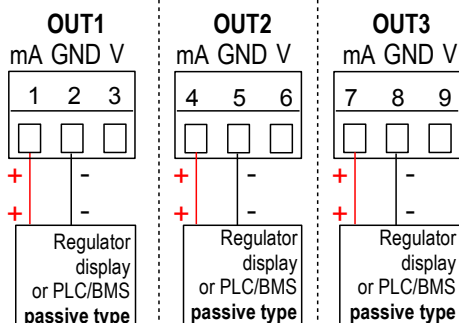
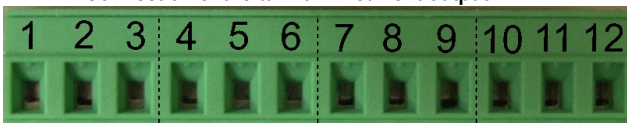

> Connection of the 0-5/10 V voltage output :

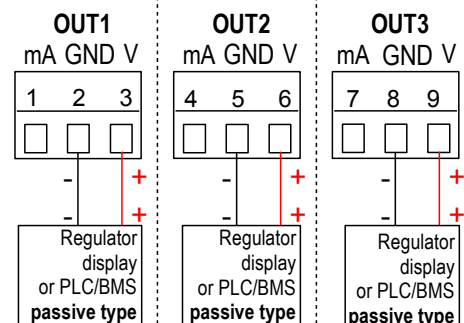
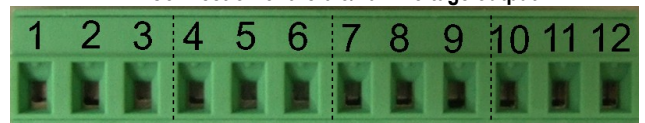

RS 485 MODBUS PROTOCOL

Class 310 transmitters can be linked in one network operating on a RS485 home bus.

The RS 485 digital communication is a 2-wire network, on which the transmitters are connected in parallel. They are connected to a PLC/BMS via the RTU Modbus communication system. Since the CPE310-S and CPE 311-S can be configured with the keypad, the MODBUS enables remote configuration, to measure 1 or 2 parameters or to see the status of the alarms...

INPUT FOR CLASS 310 INTERCHANGEABLE PROBES

The input for interchangeable probes allows to connect directly on CPE 310-S or CPE 311-S transmitter, via the adaptor cable, an interchangeable probe of the class 310 range (see technical datasheet of probes for class310 transmitters).

Advantage : the CPE 310-S and CPE 311-S centralise, in addition of the pressure, temperature and humidity measurements of a SHDI150 probe for example.

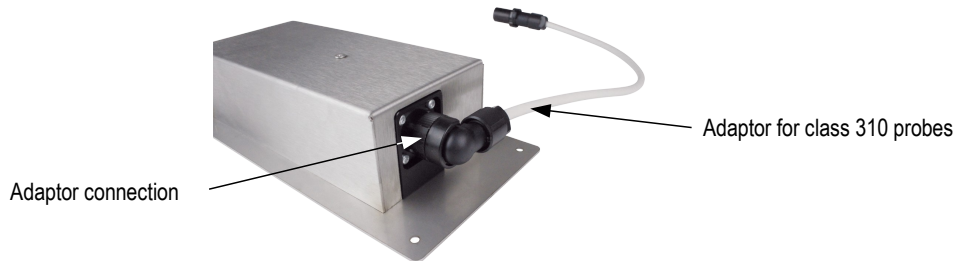

CONFIGURATION

Class 310 transmitters allows you to set all the parameters managed by the transmitter : units, measuring ranges, alarms, outputs, channels... via the different methods shown below :

- > **Via keypad**, only on models with display. A code-locking system for keypad guarantees the security of the installation. See configuration manual.
- > **Via software (optional)** : simple and user-friendly. See LCC-S user manual.
- > **Via Modbus (optional)** : configuration of all parameters from your PC, via the supervision or data acquisition software.

MOUNTING

To install a transmitter on a wall, make a cutting of 196 x 70 mm in the wall. Then drill 4 holes around the cutting as shown beside. Insert the transmitter into the wall and fix it with the 4 screws (supplied with the transmitter).

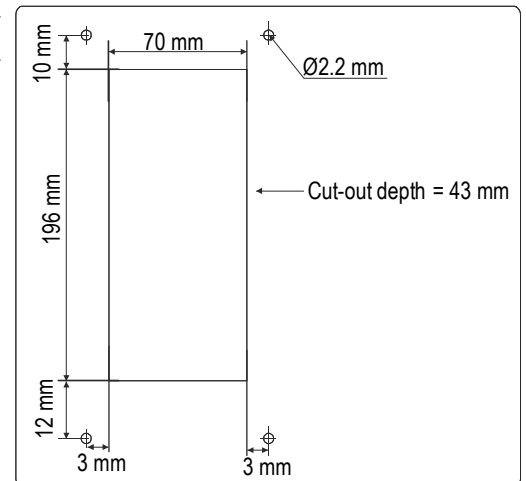

CALIBRATION

Outputs diagnostics : with this function, you can check with a multimeter (or on a regulator/display, or on a PLC/BMS) if the transmitter outputs work properly. The transmitter generates a voltage of 0 V, 5 V and 10 V or a current of 0 mA, 4 mA, 12 mA and 20 mA

Certificate : transmitters are supplied with an individual adjusting certificate and can be supplied with a calibration certificate as an option.

MAINTENANCE

Avoid aggressive solvents. When cleaning rooms or ducts with products containing formol, protect the the transmitter.

OPTIONS

- **LCC-S** : configuration software with USB cable
- **RS5** : RS 485 Protocol Modbus digital output
- **HRP** : high resolution (example in pressure : 0.1 Pa) for CPE 310-S
- **Calibration certificate**
- Sliding fittings
- Connection fitting
- Clear tube
- Pressure connections
- Trough-connections



Only the accessories supplied with the device must be used.

PRECAUTIONS FOR USE

Please always use the device in accordance with its intended use and within parameters described in the technical features in order not to compromise the protection ensured by the device.



Once returned to KIMO, required waste collection will be assured in the respect of the environment in accordance with European guidelines relating to WEEE.

www.kimo.fr

Distributed by :



EXPORT DEPARTMENT

Tel : + 33. 1. 60. 06. 69. 25 - Fax : + 33. 1. 60. 06. 69. 29

e-mail : export@kimo.fr